

DYNAPAC

Part of the Atlas Copco Group

CA262 Single Drum Soil Compactor



Technical data

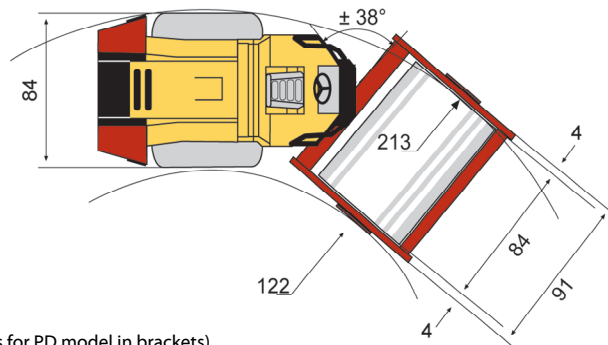
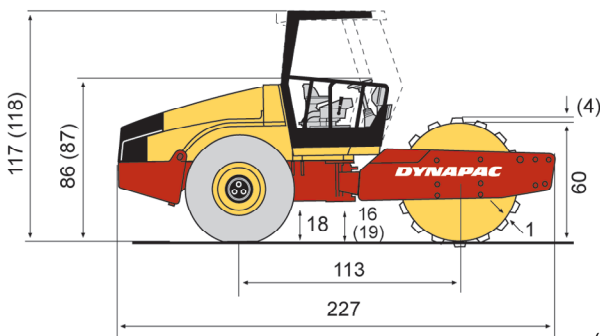

(Measures for PD model in brackets)

Weights (lbs)	CA262 D	CA262 PD
Max. operating weight	30,870	31,310
Operating weight (incl. ROPS)	23,595	26,680
Front module weight	12,350	15,435
Rear module weight	11,245	11,245
Traction		
Speed range (mph)	0 - 9	0 - 9
Number of pads	-	150
Pad area (sq. in.)	-	23
Vertical oscillation (°)	±9	±9
Tyre size (8 ply)	23,1x26	23,1x26
Theor. gradeability (%)	60	60
Compaction		
Static linear load (pli)	147	-
Nominal amplitude, high/low (in)	0.069/0.033	0.061/0.030
Vibration frequency, @ high/low amplitude (vpm)	1,980/1,980	1,980/1,980
Centrifugal force, @ high/low amplitude (lb)	55,190/26,775	67,850/32,865
Engine		
Model		Cummins QSB 6.7 T3
Type		Water cooled turbo Diesel with After Cooler
Rated power, SAE J1995, @ 2,200 rpm, hp		150
Fuel tank capacity (gals)		84
Hydraulic system		
Driving	Axial piston pump with variable displacement and Axial piston motor with variable displacement. Axial piston motor with constant displacement.	
Vibration	Axial piston pump with variable displacement and Axial piston motor with constant displacement.	
Steering	Gear pump with constant displacement.	
Service brake	Hydrostatic in forward and reverse lever.	
Parking/Emergency brake	Failsafe multidisc brake in drum gear box and in rear axle.	
Standard equipment		
Adjustable seat, Brake release system, Dual speed drum, Fuel gauge, Horn, Hourmeter, Hydraulic pressure checkpoints, Interlock, Lifting points, Limited slip on rear axle, Lockable enging hood, Lockable instrument panel cover, Main battery switch, ROPS, Rubber mounted operators platform, Tilt steering wheel, Tractor tire (PD), Vandal protected filler caps, 3" seat belt		

Find your local dealer at www.dynapac.com

We reserve the right to change specifications without notice. Photos and illustrations do not always show standard versions of machines.
The above information is a general description only, all informations are supplied without liability.